

COMMERCIAL SPECIFICATIONS FOR UNDERGROUND PRIMARY SERVICE



Customer: _____

WR# _____

Electrician: _____

Date: _____

Engineer or Architect: _____

Phone# (____) _____ - _____

The following will apply for all commercial underground jobs:

1. Customer must provide a four inch (4") conduit with a pull string from transformer location to dip pole. The trench will have a minimum of forty-eight inches (48") of cover over primary raceway from finished grade. Conduit must be schedule 40 PVC, must be gray in color, meet NEMA TC-2 requirement and be labeled as "ELECTRICAL....NEMA TC-2". Customer will install forty-eight inch (48") radius bends at all 90 Degree turns mainly when coming up into the transformer primary compartment and up the dip pole. *(See page 3)*
2. Sewer lines which parallel primary electrical raceways shall have a horizontal clearance of not less than twenty-four inches (24") from the sewer line to the nearest electrical raceway. Any other foreign utility (water, gas, telephone, etc.) paralleling primary electrical raceway shall have vertical clearances of not less than twelve inches (12") above the nearest electrical raceway. Where the twelve inches (12") minimum vertical clearance cannot be provided, a twenty-four inch (24") horizontal clearance from the nearest electrical raceway shall be maintained.
Do not cover conduit until trench is inspected by AEP representative, contact AEP (877) 373-4858.
3. Customer to provide concrete pad for pad mounted transformer according to AEP specifications.
Do not pour concrete until forms are inspected by AEP representative, contact AEP (877) 373-4858.
4. At the transformer, beyond the secondary terminations, the customer is to provide all secondary distribution facilities. AEP allows a maximum of eight (8) total, four inch (4") diameter conduits, with one circuit per conduit. *(See page 2 & 3)*
5. All transformer locations must be accessible to AEP personnel and service vehicles for the installation, maintenance and replacement of all facilities owned by AEP. The access lane must be capable of sustaining a specified weight determined by the size of the transformer and required Service vehicle.
6. Customer must provide a minimum unobstructed clearance around the pad mount transformer:
Front - Ten Feet (10')
Sides - Three Feet (3') *(See page 1)*

If location allows possible damage to installation from vehicular traffic, customer shall provide protection around pad mount transformer. *(See page 6)*
7. AEP requires a specific easement for all underground commercial installations. For AEP to create the easement, customer will provide a recorded WARRANTY DEED of the property and have a professional licensed surveyor provide a stamped survey of the easement area. All AEP easements for primary cable are a minimum of ten feet (10') in width (unless otherwise specified) and run the length of the facilities. The easement area for a Three Phase Pad Mount Transformer is 15' x 15'.
8. In case of a problem, the above customer may contact **AEP at (877) 373-4858**. Twenty-Four (24) hours advance notice is required.

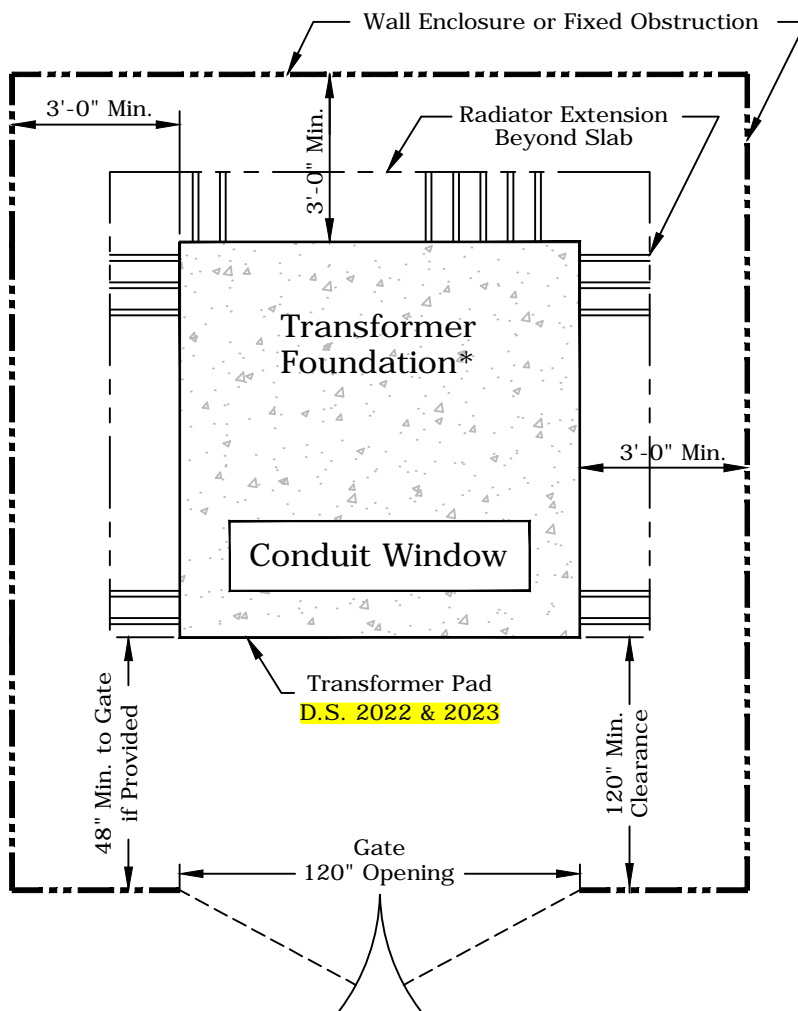

1. Transformer location must allow for access by service vehicles and must provide a minimum unobstructed clearance of 10 feet in front of Primary Cable Compartment and 3 feet ventilation space on other 3 sides.

Access to Transformer must be available to AEP at all times. Locked gates shall allow for AEP padlock as well as the owner's padlock.

If the location would allow possible damage to installation from vehicle traffic, 48 inch minimum height Bollards (see page 5) or a protective enclosure shall be provided.

2. A fence or Protective Enclosure is not required around the Transformer Installation by the Company or Industry Safety Codes, however, if one is to be installed, it must comply with AEP Safety Requirements and shall be submitted for approval prior to construction.

Any enclosure and/or shrubbery must allow for adequate air movement for cooling requirements of the Transformer and all masonry enclosures should have pierced openings for ventilation, and should not be over 8 feet in height.

* Upon request of AEP, the window will be filled with grout to prevent animals and snakes from entering the cabinet

* As specified by AEP Engineering for each Transformer location.

THREE PHASE PAD-MOUNTED TRANSFORMER - ENCLOSED BY WALL OR FENCE

Date:
04/10/2026

Revised Date:
04/10/2026

Scale:
None

Page 1 of 6

AMERICAN ELECTRIC POWER COMPANY
DISTRIBUTION STANDARDS

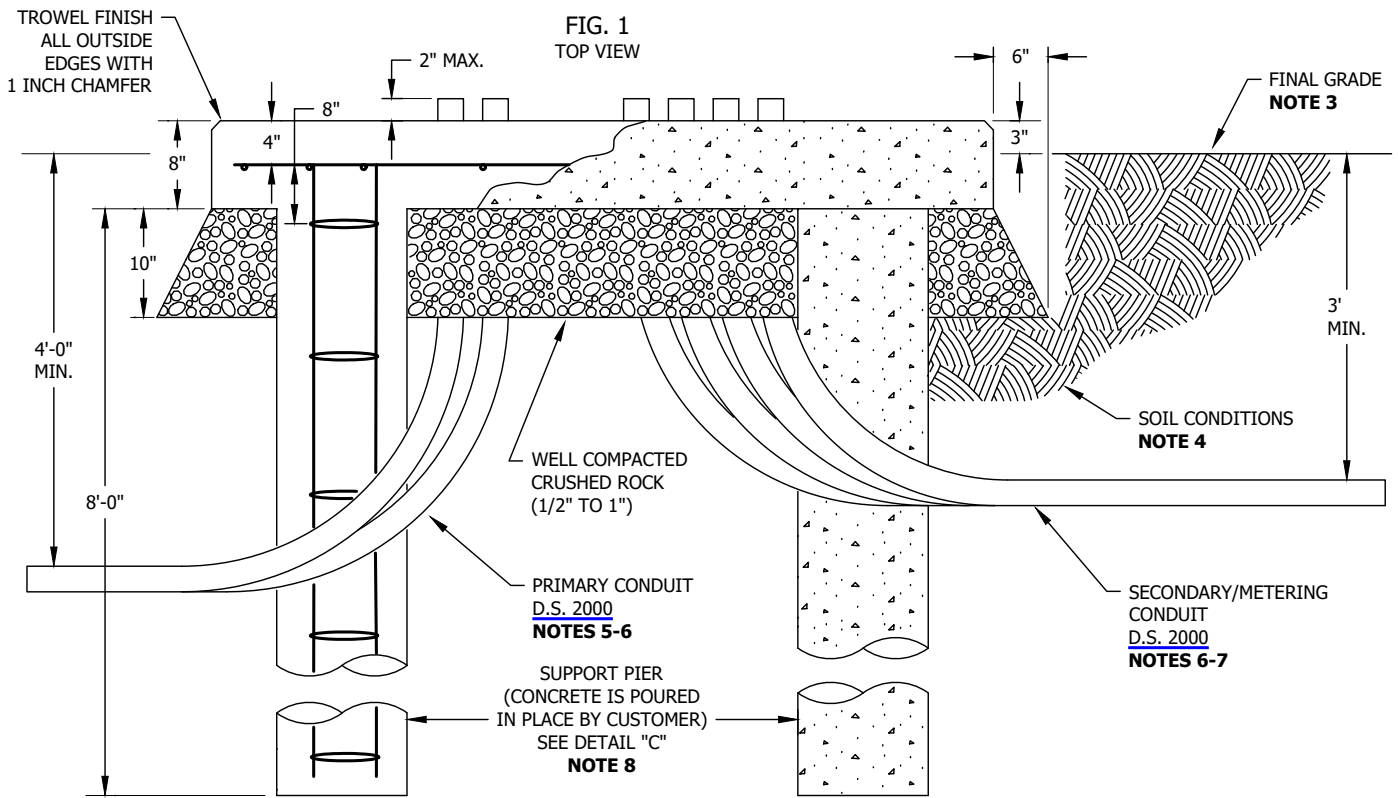
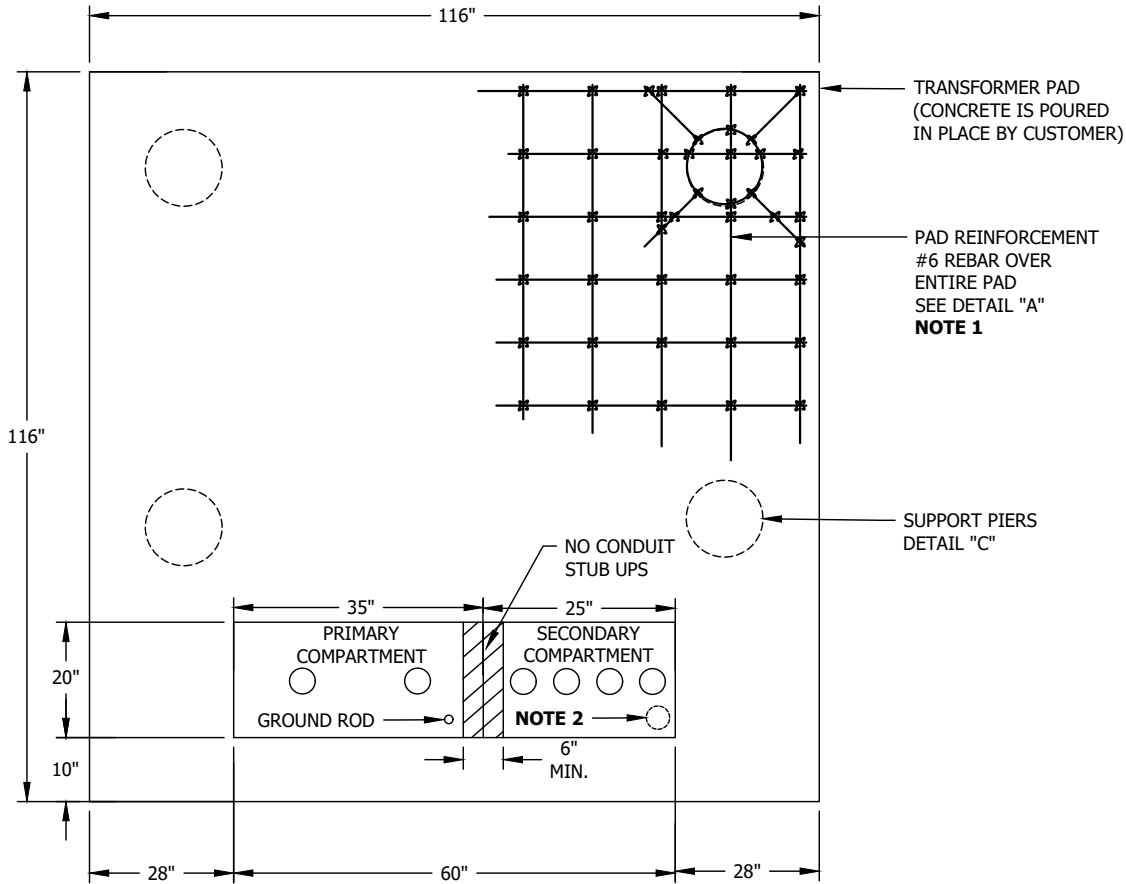
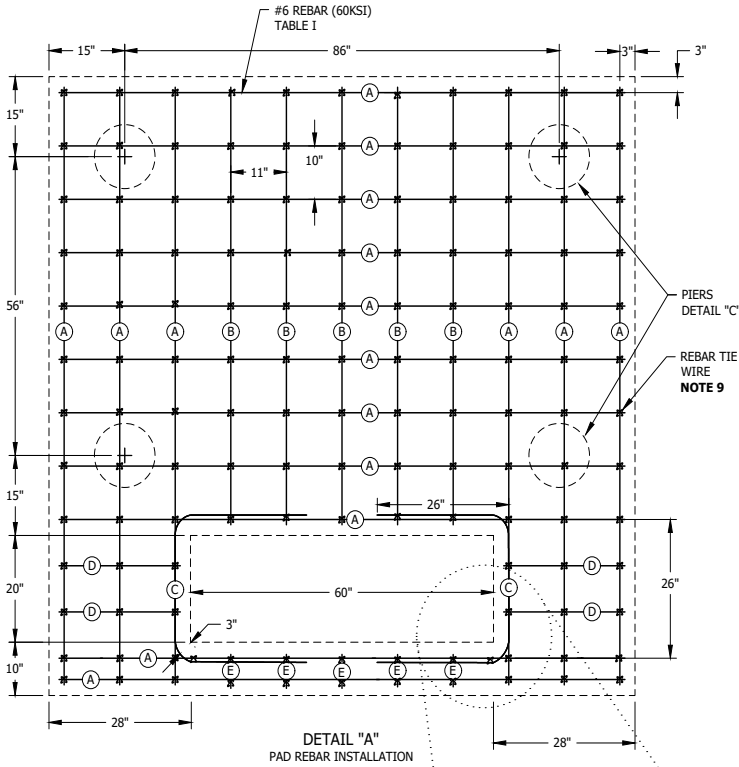

FIG. 2
SIDE VIEW

LARGE CONCRETE PAD AND PIERS FOR THREE PHASE PAD-MOUNTED TRANSFORMER
1000 KVA - 2500 KVA, 277/480 VOLT

**AMERICAN ELECTRIC POWER COMPANY
DISTRIBUTION STANDARDS**



**TABLE I
REBAR LAYOUT FOR PAD**

SIZE	IDENTIFIER	QUANTITY	LENGTH EACH (INCH)	APPROX. TOTAL WEIGHT (LBS)
#6 REBAR (60 KSI)	A	17	112	238.3
	B	5	82	51.3
	C*	2	74	18.5
	D	4	24	12
	E	5	6	3.8

* REBAR "D" TO BE BENT AS SHOWN IN DETAIL "B" FOR EACH SIDE OF COMPARTMENT.

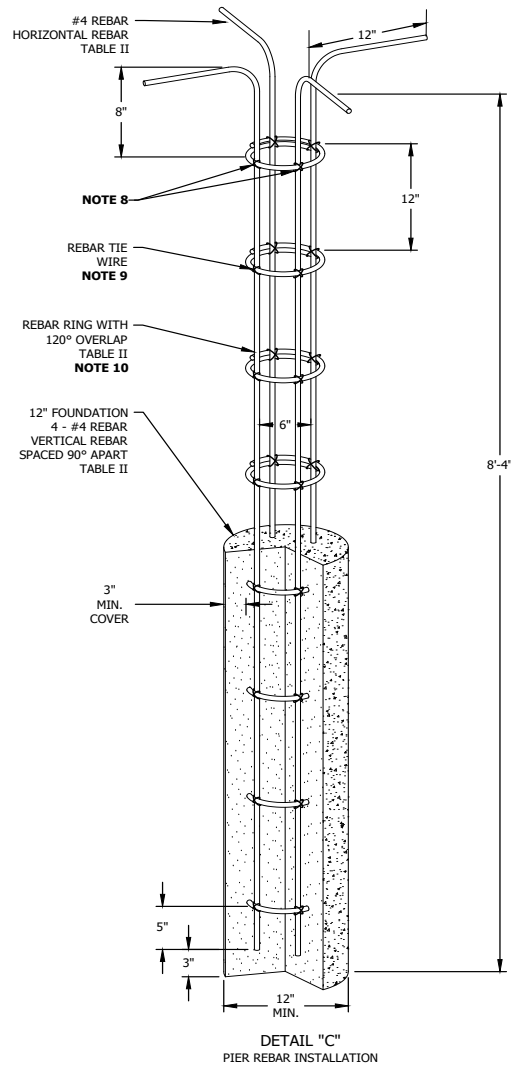
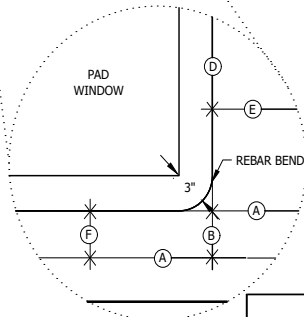

**TABLE II
CONCRETE PIER REBAR DETAILS**

DIMENSIONS & VOLUME			VERTICAL REBAR			HORIZONTAL REBAR			
			#4 REBAR (60 KSI)			#4 REBAR (60 KSI)			
PIER DIAMETER (IN)	EMBEDDED DEPTH (IN)	APPROX. CONCRETE VOLUME (CY)	QUANTITY	LENGTH EACH (IN)	APPROX. TOTAL WEIGHT (LBS)	QUANTITY	LENGTH EACH (IN)	SHAPE	APPROX. TOTAL WEIGHT (LBS)
12	96	0.23	4	109	25	9	25.25	6" RING WITH 1/3 OVERLAP (120°)	13

NOTES:

- SLAB REINFORCEMENT SHALL BE #6 REBAR ON CENTER (OC) SPACING TO FOLLOW DIMENSIONS SHOWN IN FIGURE 2 AND DETAIL "A" WITH 4" OF VERTICAL COVER. REINFORCING BARS SHALL CONFORM TO ASTM A615 GRADE 60. CONCRETE SHALL HAVE A MINIMUM COMPRESSIVE STRENGTH OF 4000 PSI AFTER 28 DAYS.
- FOR GUIDELINES ON THE INSTALLATION OF AN INSTRUMENT TRANSFORMER REFER TO THE METER AND SERVICE GUIDE.
- FINAL PAD INSTALLATION SHALL BE LEVEL AS MEASURED BY CARPENTERS LEVEL FOR ALL DIRECTIONS.
- CONCRETE PAD WITH PIERS IS TO BE INSTALLED ONLY WHEN HIGH VOLUME CLAY OR SAND TYPE SOILS ARE ENCOUNTERED. THESE SOIL TYPES ARE CHARACTERIZED BY EXTREME SURFACE CONDITION VARIATIONS OVER TIME. WHERE SOIL IS FOUND TO BE TOTALLY BEDROCK, SHALE OR HARDPAN, ELIMINATE DRILLED PIERS AND REFER TO [D.S. 2020](#), [D.S. 2021](#), [D.S. 2024](#) OR [D.S. 2025](#).
- PRIMARY CONDUIT NUMBER, SIZE, LOCATION AND DIRECTION TO BE SPECIFIED BY AEP ENGINEERING. CONDUIT ELBOW CAN BE SCH 40 OR 80, MUST BE GRAY IN COLOR, MEET NEMA TC-2 REQUIREMENT AND BE LABELED AS "ELECTRICAL...NEMA TC-2", MINIMUM BEND OF 90°, MINIMUM 36 INCH RADIUS TO AVOID DISTURBING THE GROUND UNDER THE REAR OF THE PAD AND TO MINIMIZE SETTLING, CONDUIT SHOULD BE INSTALLED TO THE FRONT OR SIDE WHENEVER POSSIBLE AND MARK THE CONDUIT END LOCATIONS WHEN APPLICABLE.
- CONDUITS SHALL BE ROUTED IN A MANNER THAT ALLOWS ROOM FOR A GROUND ROD TO BE INSTALLED WITHOUT DAMAGING THE CONDUIT.
- THE NUMBER AND PLACEMENT OF SECONDARY/SERVICE/METERING CONDUITS AND SIZE OF SERVICE CABLES TO BE DETERMINED BY AEP ENGINEERING AND THE CUSTOMERS ENGINEERING FIRM. SECONDARY CONDUIT MAY EXTEND IN ANY DIRECTION AS REQUIRED BY THE CUSTOMER.
- PIERS SHALL BE 12" MINIMUM DIAMETER, 8' DEEP WITH 4 - #4 VERTICAL REBARS AT 9'-1" LONG, #4 HORIZONTAL REBAR AT 12" ON CENTER (OC), AND PROVIDE A MINIMUM 3" COVER. THE #4 BENT REBARS SHOULD BE 12" LONG IN THE HORIZONTAL DIRECTION AND TIE IN WITH THE PAD REBAR
- ALL REBAR SHALL BE TIED TO STANDARD REBAR TIE WIRE.
- FORM HORIZONTAL REBAR IN RING OF 6" FOR 12" PIER, AND OVERLAP 120° (1/3 OF THE CIRCUMFERENCE).

**LARGE CONCRETE PAD AND PIERS FOR THREE PHASE PAD-MOUNTED TRANSFORMER
1000 KVA - 2500 KVA, 277/480 VOLT**

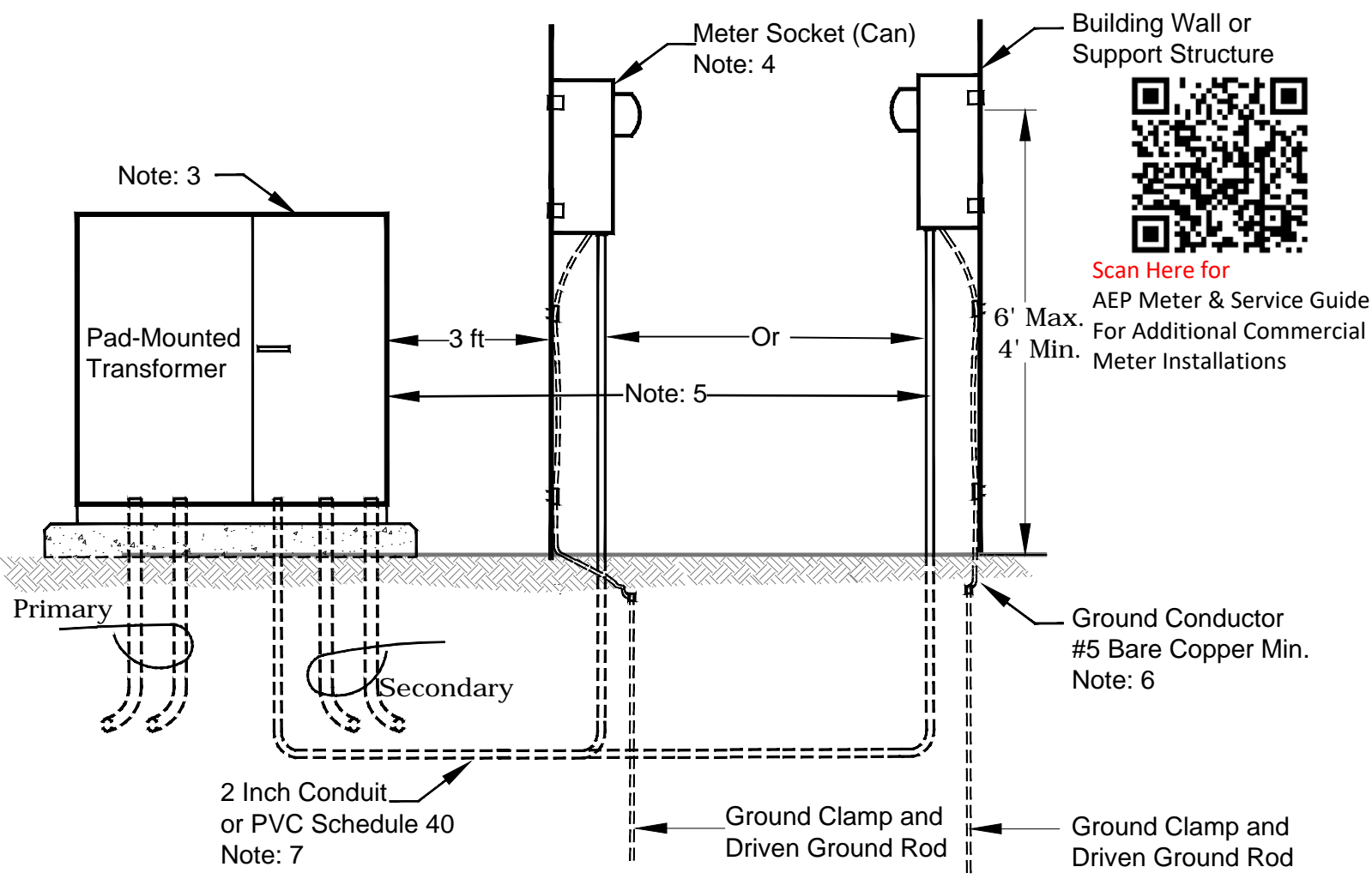

NOTES:

1. Instrument Transformers (CTS) are furnished and installed by Company prior to connection of customer service cables.
2. Customer shall provide NEMA type Terminal Lugs for customer owned service conductors where required. Power company to secure cable terminations. Stacking lugs may be required to accommodate the number of service conductors per transformer bushing.
3. This standard application for a single customer Three Phase Pad-Mounted Transformer.
4. Customer provides Meter Socket to be installed by customer or contractor in a Plumb Position at location, using removable corrosion resistant fasteners. All Meter Sockets installed in the Company's service territory shall be of a type approved by the company and meet all requirements in construction and features. In addition, Meter Sockets purchased by the Customer shall be UL listed and labeled in accordance with National Electric Code.
5. Transformer Pad location and the location of conduits for Conductor/Meter Control Cable to be specified by AEP. The Meter location is to be within 15 feet of the Transformer Pad location. When the building is located at a distance greater than 15 feet from the Transformer Pad location, the Meter is to be mounted on a support structure at a location where the distance from the Transformer Pad location is not greater than 15 feet, but at least 3ft away from pad For free standard Metering.
6. The Meter Socket shall be grounded. The Meter Socket shall be bonded through a separate equipment-Grounding Conductor connected to the grounded service conductor (usually the neutral). In some jurisdictions the grounding of the Meter Socket will be supplemented with the use of a driven Ground Rod in addition to bonding to the Grounded Service Conductor.
7. Schedule 80 Conduit required for driveways and parking lots.

Three Phase Pad-Mounted Transformer & Metering Installation



Date: 04/10/2026	Revised Date: 04/10/2026	Scale: None	Page 4 of 6
----------------------------	------------------------------------	-----------------------	--------------------

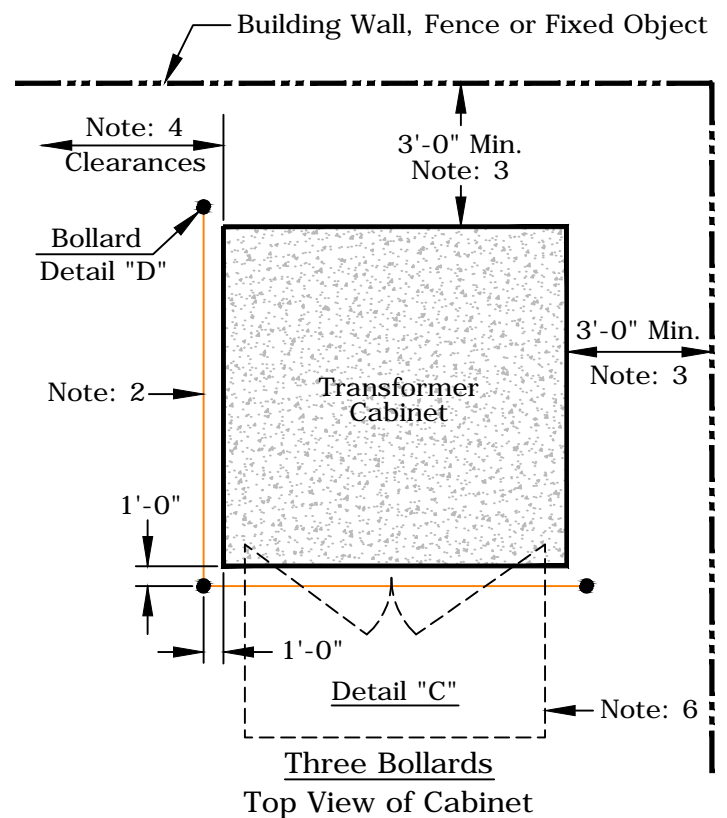
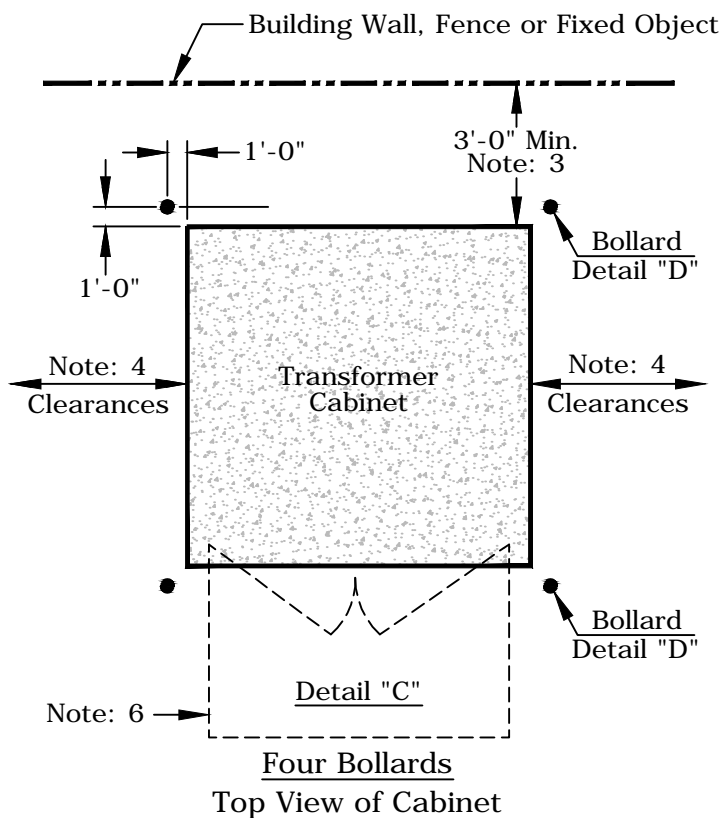

Notes:

1. Bollards shall be used where vehicular traffic may cause damage to the padmount, i.e. parking lots, loading areas, driveways, etc.
2. When additional protection is required, guy wire or rails may be installed between bollards.
3. The pad should be located 4'-0" from the building on the side where the metering equipment is located or the conduits enter the building to permit free spacing for conduit bends.
4. Doors, windows, window walls, fire escapes, entrances and ventilating ducts located at ground floor, and at multiple stories as well, should be avoided in the location of the pad. Avoid placing pad under building overhang such as wide eaves unless building is of fire proof construction.
 Recommended Minimum Lateral Clearances:
 Clearances to doors, windows, entrances and ventilating ducts - 5'-0"
 Clearance to fire escapes - 20'-0"
5. In non-paved areas use crushed stone or sod to provide for a four inch (4") covering over the concrete encircling the bollard.
6. Maintain clear area in front of padmount transformer doors at least as wide as the doors and 10 feet deep. Also, if padmount transformer has current limiting fuses at the side of live front cabinet, maintain adequate operating space for these as well.
7. Paint bollards "Safety Yellow" and install reflective safety tape.

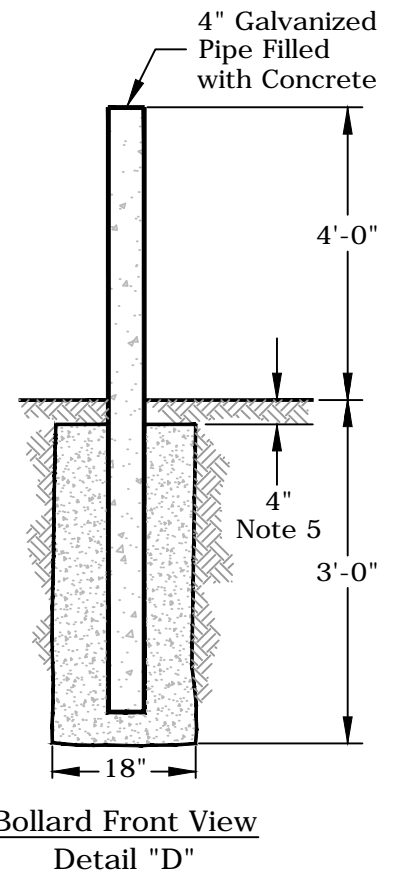

Three Phase Transformer Pad and Bollard Location



An AEP Company

Date: 04/10/2026

Revised Date: 04/10/2026

Scale: None

Page 5 of 6

Standard Easement Width

Easement Parallel and Adjacent to Property Line

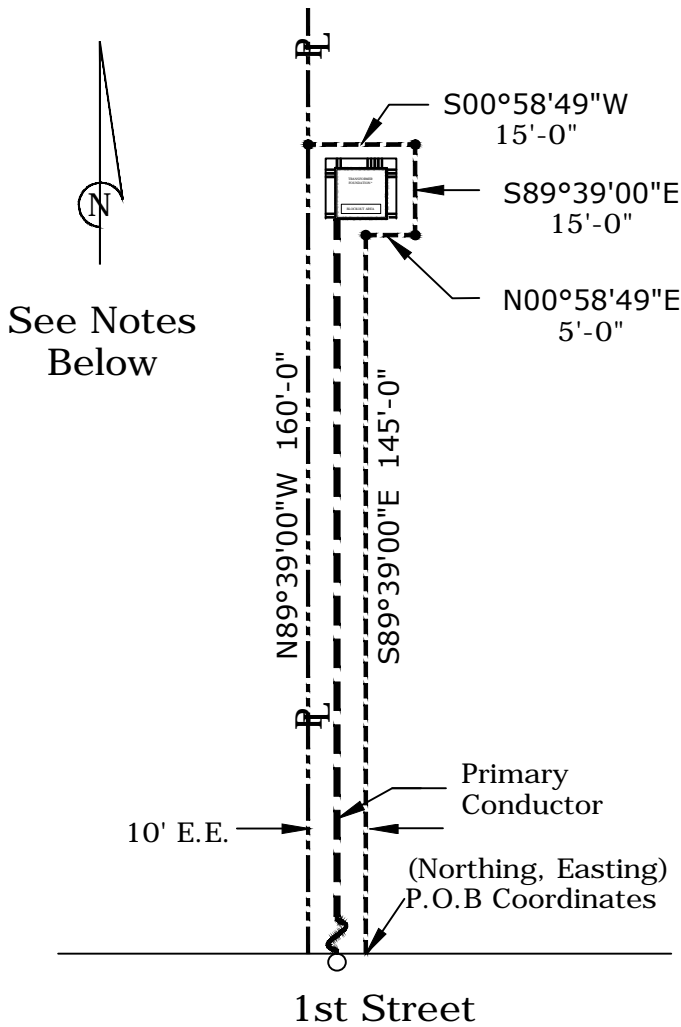

Easement Projects into Property

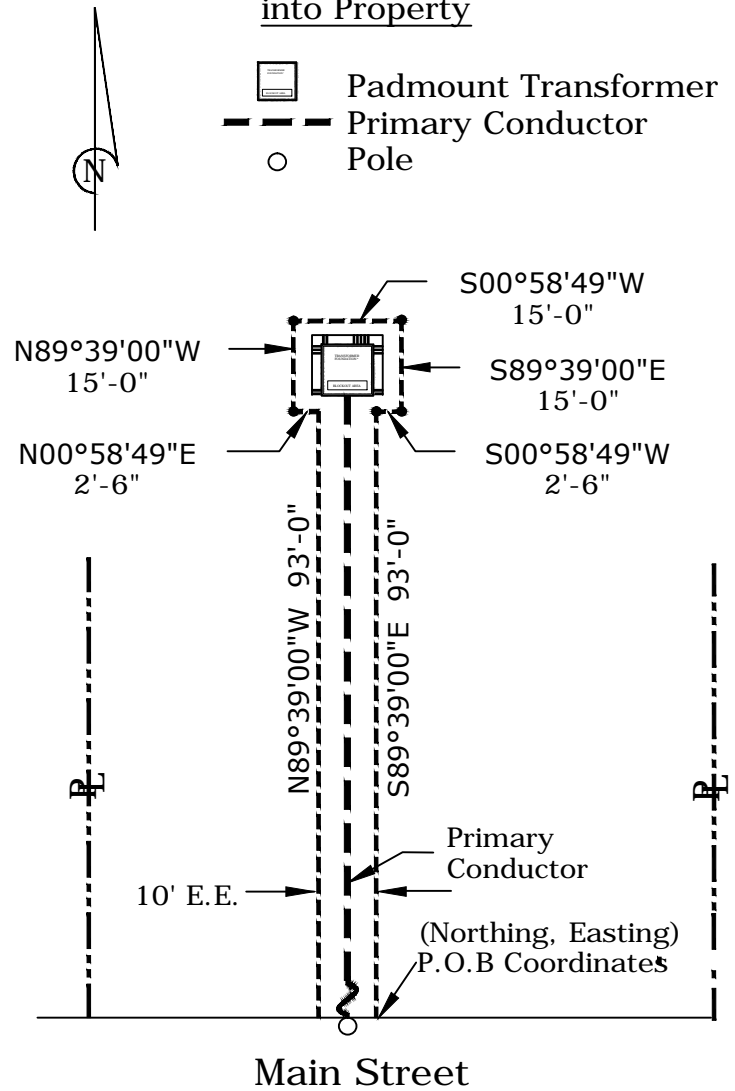

Notes:

1. Maintain clear area to front of Transformer Doors at least as wide as the doors and 10 feet deep.
2. Use Bollards where vehicular traffic may cause damage to the Transformer, i.e., parking lots, loading areas, driveways, etc.
3. Minimum Easement width for an AEP Primary run is 10 feet.
4. Minimum Easement width for an AEP Three Phase Transformer Pad is 15 feet by 15 feet.
5. Easements above are required to be surveyed by Certified Surveyor; Metes & Bounds description of the Easement Area must accompany these.

Three Phase Padmount - Easement Dimensions



Date: 04/10/2026

Revised Date: 04/10/2026

Scale: None

Page 6 of 6